

MAINLINE SIZE mm	A mm	B mm	C mm	D mm	ØE mm	ØF mm	G mm	H mm	BODY WEIGHT Kgs
DN8	45.0	50.8	7.8	17.5	13.5	10.3	37.0	133.0	0.3
DN10	53.0	50.8	9.6	20.0	17.2	14.0	37.0	149.0	0.4
DN15	55.0	50.8	11.7	22.0	21.3	18.1	37.0	153.0	0.4
DN20	68.5	50.8	14.5	24.6	26.9	23.7	37.0	180.0	0.5
DN25	78.0	50.8	17.2	27.0	33.7	29.7	50.5	212.5	1.0
DN32	87.5	50.8	21.8	30.0	42.4	38.4	50.5	231.5	1.3
DN40	97.0	50.8	24.8	32.0	48.3	44.3	50.5	250.5	1.5
DN50	76.0	50.8	30.2	35.0	60.3	55.1	50.5	208.5	1.7
DN65	95.0	50.8	38.1	40.0	76.1	70.9	50.5	260.5	2.3
DN80	114.0	50.8	44.5	48.0	88.9	83.7	50.5	298.5	3.2
DN100	152.0	50.8	57.2	60.0	114.3	109.1	50.5	374.5	4.9

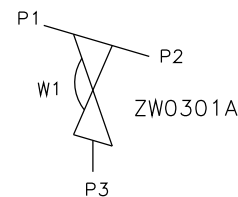

ORIENTATION AS PER
P&ID DIAGRAM FOR
OPTIMUM DRAINABILITY.

The information on this sheet is Private and Confidential and is the property of Crane Process Flow Technologies Limited and must not be published directly or indirectly in any manner whatsoever without the written permission of the Company and must not be used in any way detrimental to their interests.
© Crane Process Flow Technologies

CRANE Process Flow Technologies
A Crane Co. Company

Saunders
The Science Inside

Title
SCHEDULE OF LEADING DIMENSIONS FOR
DN8 WEIR POINT OF USE 'T' BODY WITH
ISO 1127 S1 BUTT WELD ENDS

Drawn R1	Date 10.04.12	UNCONTROLLED IN HARD COPY FORMAT	
Checked RND	Date 10.04.12	Drawing No.	Issue.
First Angle Projection Method E	DO NOT SCALE	WEB-176	1

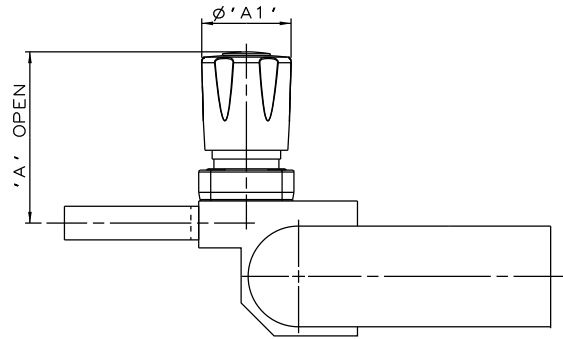

PURE PERFORMANCE
BONNET ASSEMBLY

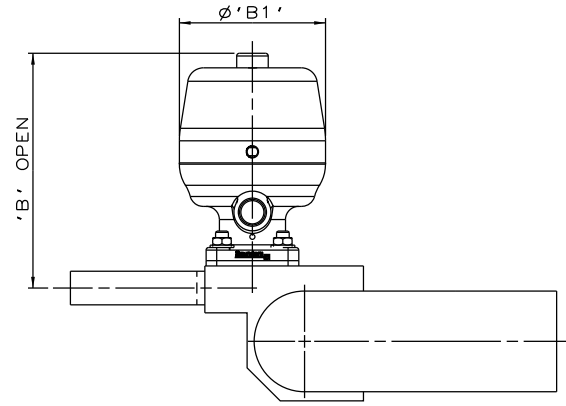

*S360 ACTUATOR

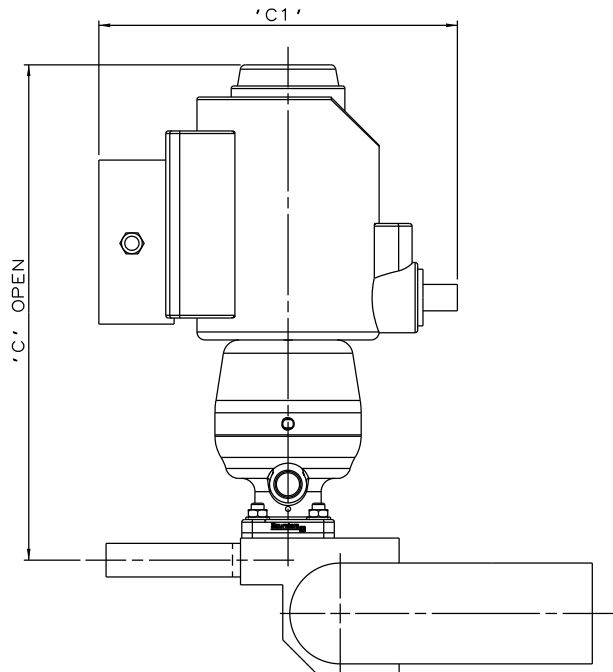

*S360 ACTUATOR
WITH I-VUE SENSOR

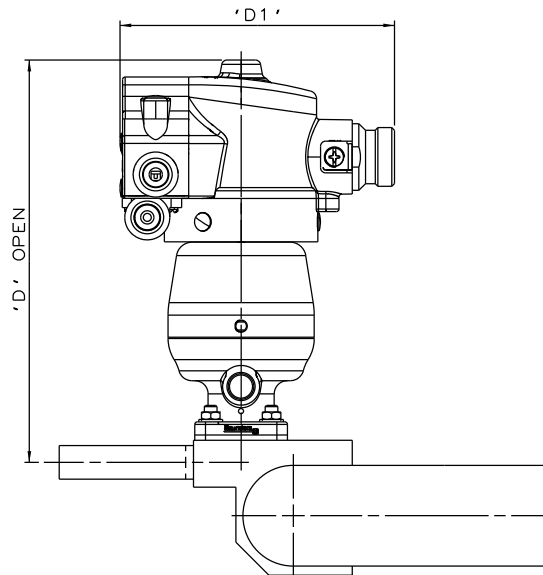

*S360 ACTUATOR
WITH M-VUE SENSOR

The information on this sheet is Private and Confidential and is the property of Crane Process Flow Technologies Limited and must not be published directly or indirectly in any manner whatsoever without the written permission of the Company and must not be used in any way detrimental to their interests.

© Crane Process Flow Technologies

CRANE Process Flow Technologies
A Crane Co. Company

Saunders
The Science Inside

Title
SCHEDULE OF LEADING DIMENSIONS FOR DN8/0.25 WEIR
'T' BODY (DN8/0.25 BRANCH) WITH BUTT WELD ISO 1127 S1
ENDS, FITTED WITH TOPWORKS OPTIONS

Drawn R1	Date 09.05.17	UNCONTROLLED IN HARD COPY FORMAT	
Checked RND	Date 09.05.17		
First Angle Projection Method E	DO NOT SCALE	Drawing No. WEB-176-ASSY	Issue. 1

* DIMENSIONS SHOW MAXIMUM ENVELOPE FOR ALL MODES

BRANCH SIZE		A		A1		B		B1		C		C1		D		D1	
mm	inch	mm	inch	mm	inch	mm	inch	mm	inch	mm	inch	mm	inch	mm	inch	mm	inch
DN8	0.25	65.2	2.57	34.0	1.34	88.8	3.50	55.0	2.18	187.8	7.39	136.0	5.35	153.8	6.06	103.8	4.09